

Gabaritos das aulas

1 a 30

Aula 1 - Nice to meet you!

Exercício 1

- Quadro 1 - Good morning!
Quadro 2 - Hi! HELLO!
Quadro 3 - My NAME IS Martha.
I'm Bob.
Quadro 4 - How ARE YOU?
I'm fine, thanks. AND YOU?
Fine. THANK YOU.

Exercício 2

Logo depois do almoço, diz: Good AFTERNOON!
Está anoitecendo, diz: GOOD EVENING!

Exercício 3

- a) My name IS Tom.
b) I AM Washington.
c) My name IS Diana.
d) I AM Nei.

Aula 2 - What is your name?

Exercício 1

- 0 zero
1 one
2 two
3 three
4 four
5 five
6 six
7 seven
8 eight
9 nine

Exercício 2

- a) five two five three one oh eight

Exercício 3

My name is Mark Simpson.
I'm a teacher.
Rua Grécia, 32.
246-7124

Exercício 4

- a) (your name)
b) (your address)
c) (your telephone number)

Aula 3 - Hello!

Exercício 1

Who is it?

What is your telephone number?

Exercício 2

- a) Could you speak a little slower?
- b) Pardon me? ou
Could you repeat that please?
- c) Hold on, please ou
Just a moment, please.
- d) She/He is not here right now.

Exercício 3

- a) I AM a teacher.
- b) This is Martha. She IS a secretary.
- c) John IS my co-worker.
- d) You ARE my friend.
- e) It IS a book.

Aula 4 - May I help you?

Exercício 1

- a) \$ 79.95 (plus \$ 2.00 shipping)
- b) 800 - 432-5407
- c) 24 hours a day; 7 days a week.

Exercício 2

Sugestões: Balconista em loja. Recepcionista para pessoa que chega. Pessoa em balcão de informações. Guias turísticos.

Exercício 3

- 1) This is a book.
- 2) This is a telephone.
- 3) This is a ball.
- 4) This is a house.
- 5) This is a tree.
- 6) This is a bike.

Aula 5 - Manuals

Exercício 1

Nome dos botões:

- 19 - TAPE
- 20 - ON/OFF
- 21 - VOLUME
- 22 - STOP/PLAY
- 23 - FF
- 24 - REW
- 25 - REC

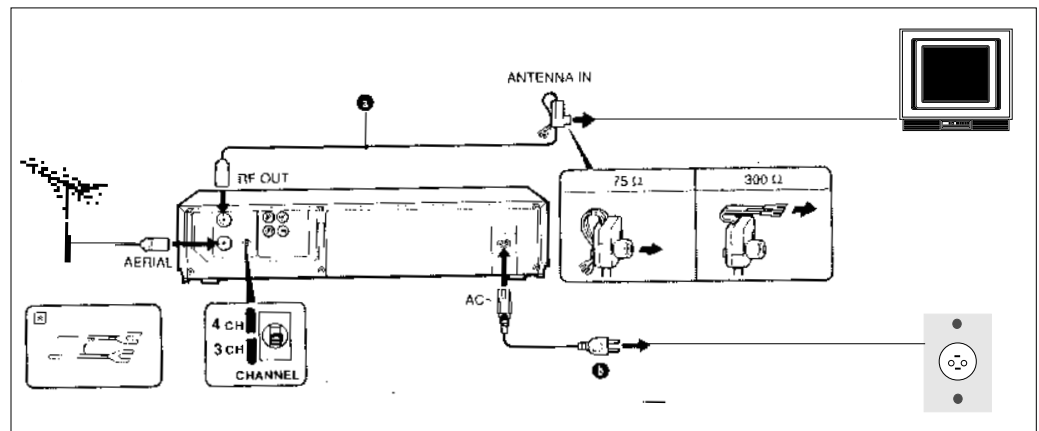

Aula 6 – Stop, listen and learn

Agora é a sua vez de usar o imperativo:

- a) Resposta pessoal. Sugestões: nas instruções de manual, nas receitas, nas placas de sinalização, etc.
- b1) FOLD it diagonally.
- b2) FOLD it in the middle.
- b3) UNFOLD it.
- b4) FOLD it like this.

Aula 7 – Press the button

Exercício 1

Verbos no imperativo:

CONNECTING ANTENNA-VCR-TV	USE OUR OVEN
<p>When your TV is not equipped with audio/video inputs:</p> <ol style="list-style-type: none"> 1. <u>Remove</u> the VHF/UHF TV antenna coaxial cable from the TV receiver and <u>connect</u> to this unit. 2. <u>Connect</u> this unit to the TV receiver using the supplied 75 ohm antenna cable (a) which is also applicable to the 300 ohm connector. If the TV receiver has a 300 ohm connector, <u>pull out</u> the ends for the 300 ohm connector at the rear of the plug. 3. <u>Connect</u> the supplied power cord (b) to the AC inlet of this unit and to a wall outlet. <p>Now the TV receiver is ready to receive TV broadcast as well as video programs from this unit.</p>	<ol style="list-style-type: none"> 1. Plug in - Plug in a properly grounded electrical outlet. 2. Press Stop/Reset Pad - You may set the clock instead of pressing this pad. 3. Press Door Release Button - <u>Open</u> the door and <u>place</u> a cup of water on the glass tray in the oven. Then <u>close</u> the door. 4. Press Power Level Pad 5. Press Time Pad 6. Press Start Pad <p>The next operation for you to press is indicated by the blinking mark.</p> <p><small>lb/kg Conversion: The oven automatically displays the lbs/oz symbol when using Auto Defrost feature etc. If you wish to use de kg/g, press Start Pad directly after plugging the oven in but before setting the clock.</small></p>

Exercício 2

CONNECTING ANTENNA-VCR-TV

Remove – remova, tire

Connect – faça a conexão, junte

Pull out – puxe para fora, retire

USE OUR OVEN

Use – use

Plug in – ligue

Press – aperte, pressione

Open – abra

Place – coloque, ponha

Aula 8 – Yes, I can

Vocabulário

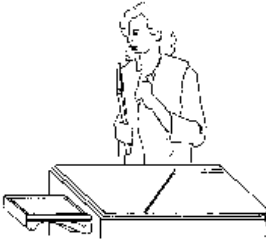
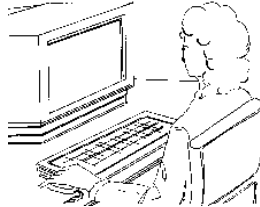
		
a) fax machine	b) xerox machine	c) computer

Exercício 1 1 (c); 2 (a); 3 (b).

Exercício 2

Sugestões para as respostas:

- a) Yes, I can ou No, I can't.
- b) Yes, I can ou No, I can't.
- c) Yes, I can ou No, I can't.
- d) Yes, I can ou No, I can't.
- e) Yes, I can ou No, I can't.

Exercício 3

- a) She can't use a computer.
- b) They can't speak French.
- c) Marcos can't swim.

Aula 9 - That's a dictionary

Exercício 1

Including - incluso (no preço)

Breakfast - café da manhã

City - cidade/ city tour - visita aos pontos turísticos da cidade.

Aula 10 - What is your occupation?

Exercício 1

- a) What is YOUR occupation? I am an office-boy.
- b) What are THEIR occupation? They are soccer players.
- c) What is HER occupation? She is a teacher.

Exercício 2

- a) I am a fireman.
- b) They are office-boys.
- c) We are actors.

Exercício 3

- a) My name IS Michael.
- b) We ARE doctors.
- c) You ARE my friend.
- d) They ARE brothers.
- e) She IS the boss.
- f) He IS a technician.
- g) I AM a student.

Aula 11 - Where do you work?

Exercício 1

- a) I WORK at *Sunshine Travel Agency*.
- b) He WORKS in a hospital.
- c) They WORK at *FIESP*.
- d) She WORKS in an office.
- e) We WORK in a circus.

Exercício 2

- a) IN an office
- b) AT *Tropical Hotel*
- c) IN a store
- d) IN a circus
- e) AT *Sunshine Travel Agency*
- f) AT *Doceria Pé-de-moleque*

Exercício 3

- a) This is A table.
- b) Mary is A secretary.
- c) Nei is AN office-boy.
- d) That is A computer.
- e) We work in A store.
- f) They are technicians.

Aula 12 - Everyday life

Exercício 1

O dia de Nei

I WORK at *Sunshine Travel Agency*. I TAKE photocopies. I GO to the bank. I ANSWER the telephone at Beth's lunch hour. I SEND letters. I STUDY at night.

Exercício 2

- a) I type letters (ou faxes).
- b) I study English.
- c) I feed the baby.
- d) I send faxes.
- e) I work at *Sunshine Travel Agency*.

Aula 13 – She works everyday

Exercício 1

O dia de Diana

She HAS breakfast at 7 o'clock a.m. She DOES the dishes. She WALKS to work. She WORKS from 9:00a.m. to 6:00 p.m. She GOES to school. She STUDIES in the evening.

Exercício 2

I play football.
I take the bus to work.
I go to school.
He studies English.
He walks to work.
He does the dishes.

Aula 14 – What a wonderful world!

Exercício 1

- 1 (d)
- 2 (a)
- 3 (e)
- 4 (b)
- 5 (c)

Exercício 2

- a) He WORKS here.
- b) She SEES skies of blue.
- c) He WAKES UP at 6 a.m..
- d) She STUDIES English.
- e) He WALKS to work.

Aula 15 – I am not John

Exercício 1

- a) (5)
- b) (3)
- c) (1)
- d) (2)
- e) (4)

Exercício 2

- a) They DO NOT WORK in São Paulo.
- b) They ARE NOT teachers.
- c) She DOES NOT WAKE UP at 6 a.m.
- d) She IS NOT a secretary.
- e) I DO NOT HAVE breakfast at 7 a.m.

Exercício 3

- a) Mary ISN'T here right now.
- b) She DOESN'T WORK at *Sunshine Travel Agency*.
- c) They AREN'T secretaries.
- d) That ISN'T a radio.
- e) I DON'T WAKE UP at 6 a.m.
- f) She ISN'T my wife.

Exercício 4

- 1) (e)
- 2) (c)
- 3) (b)
- 4) (a)
- 5) (d)
- 6) (f)

Aula16 – Be careful!

Exercício 1

- a) Don't walk.
- b) Don't plug it in.
- c) Don't run.
- d) Don't press the black button.
- e) Don't wake up before 7 a.m..

Exercício 2

AFIRMATIVA

Be careful.

Feed the baby.

Read a story to the baby.

NEGATIVA

Don't smoke.

Don't run.

Don't stop.

Aula 17 - What is this?

Exercício 1

a) Nei IS AN office-boy. He WORKS AT *Sunshine Travel Agency*.

b) O dia de Diana

I WAKE UP at 6 o'clock. I GO to work. I WORK IN a house. I TAKE care of a baby. I AM a baby sitter

Exercício 2

READ a story to the baby.

FEED the baby.

TAKE the baby to the park.

PUT the baby to sleep at 8 o'clock.

Exercício 3

a) Nei IS NOT a doctor.

b) Beth DOES NOT WORK at *Boo Moda Infantil*.

c) Ian DOES NOT SLEEP at 9 o'clock.

d) We DO NOT LIKE jiló.

e) They ARE NOT soccer players.

Exercício 4

1º balão: THIS is a lollypop.

2º balão: THAT is a telephone.

Aula 18 - Help! Help!

Exercício 1

Virgínia diz: HELP! HELP!

Exercício 2

Júlio diz: I NEED SOME HELP.

Exercício 3

Relacione as perguntas às respostas:

a) (2) b) (1) c) (4) d) (3)

Exercício 4

a) DO you need help?

c) DO they go to school?

e) What DO you need?

g) DO you love me?

b) How DOES it work?

d) DOES she like Pop Music?

f) DOES Diana work at *Sunshine Travel Agency*?

Aula 19 - How does it work?

Exercício 1

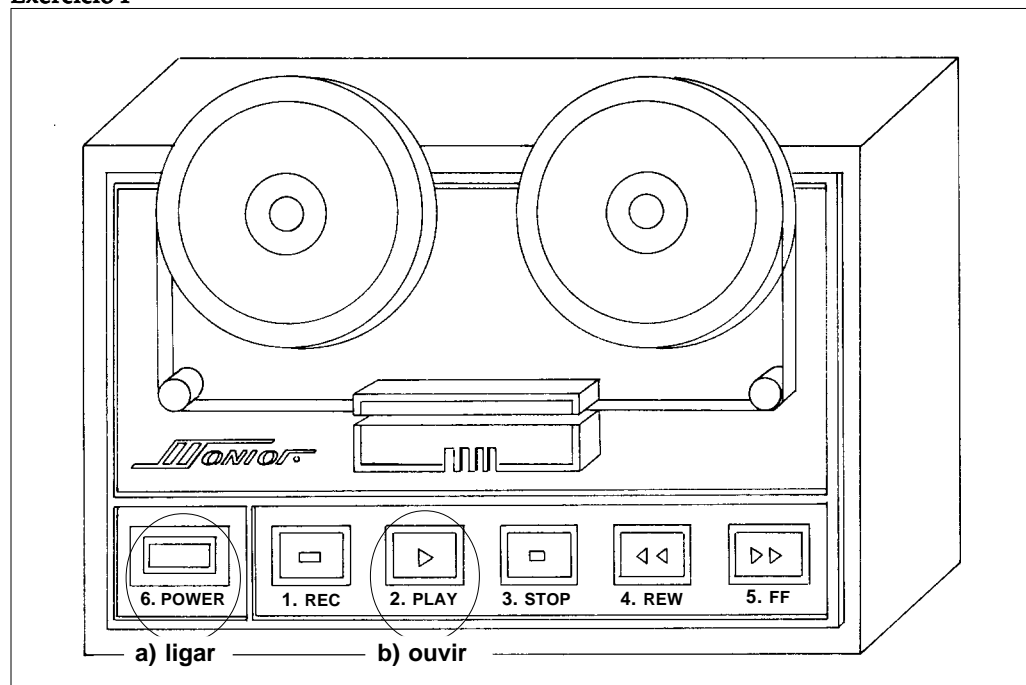

Exercício 2

1º balão: THESE ARE books.

2º balão: THOSE ARE ice-creams.

Aula 20 – Faxes and letters

Exercício 1

No fax:

- a) Quem enviou: Mrs. Longlegs.
- b) Para quem é: Mrs. Carter.
- c) A data: May, 1st, 1995.

Na carta:

- a) Quem enviou: Leonor da Silva
- b) Para quem é: Ms. Virgínia Correa
- c) A data: March 14th, 1995.

Exercício 2

- a) August 12th, 1995.
- b) November 30th, 1994.

Exercício 3

- a) 22 de maio de 1951.
- b) 24 de julho de 1976.

Aula 21 – Best before...

Exercício 1

- a) SUNDAY.
- b) MONDAY.
- c) SATURDAY.
- d) Tuesday, WEDNESDAY, Thursday.

Exercício 2

Beth está comprando a opção (c) purê.
Dica de Beth: p U R Ê de b A T A T A S.

Exercício 3

A data de validade é a opção (b) junho de 95.

Exercício 4

O produto pesa 13 OZ. (368.55 GRAMS).

Aula 22 – Recipe

Exercício 1

Os ingredientes são os da opção (b): egg, oil, milk, mix.

Exercício 2

- a) Water, butter, salt, milk, potato flakes.
- b) Heat water, butter and salt in saucepan; add cold milk and potato flakes; stir.
- c) Heat, add, stir.

Exercício 3

- a) (3)
- b) (5)
- c) (1)
- d) (4)
- e) (2)

Aula 23 – Would you like some coffee?

Exercício 1

- a) (3)
- b) (1)
- c) (2)

Exercício 2

- a) ☺ YES, PLEASE.
- b) ☺ YES, PLEASE.
- c) ☹ NO, THANKS.
- d) ☹ NO, THANKS.

Exercício 3

- a) A: WOULD YOU LIKE SOME CHOCOLATE?
B: No, thanks.
- b) A: WOULD YOU LIKE A CUP OF COFFEE?
B: Yes, please.
- c) A: WOULD YOU LIKE A PANCAKE?
B: No, thanks.

- d) A: WOULD YOU LIKE AN ICE CREAM?
B: Yes, please.

Aula 24 - I am working

Exercício 1

- a) HE IS COOKING DINNER.
- b) SHE IS STUDYING ENGLISH.
- c) WE ARE WORKING.
- d) THEY ARE WATCHING TV.
- e) I AM EATING PANCAKES.
- f) YOU ARE SLEEPING.

Aula 25 - Revisão

Exercício 1

- a) Hi! I AM Tom. I AM at *Sunshine Travel Agency*.
- b) Nei IS an office-boy.
- c) We ARE students.
- d) ARE you a doctor? No, I AM NOT a doctor. I AM a driver.
- e) ARE you tired? Yes, We ARE very tired.
- f) IS it a paperclip? Yes, it IS .
- g) We ARE Spanish.

Exercício 2

- a) SHE is a secretary.
- b) THEY are Americans.
- c) THEY are at *Sunshine Travel Agency*.
- d) WE are tired.
- e) YOU are happy.

Exercício 3

- a) MY name is Nei.
- b) What is YOUR occupation?
- c) It's HIS book.
- d) What is HER address?
- e) What is THEIR telephone number?

Exercício 4

- a) I WORK in a hospital.
- b) Mary and Júlia LIVE in New England.
- c) He FIXES the answering machine.
- d) Beth TAKES the bus at nine o'clock.
- e) Diana STUDIES English.

Exercício 5

- a) She DOES NOT GO to school in the morning.
- b) You and I DO NOT WORK at *Boo Moda Infantil*.
- c) Clara DOES NOT SPEAK French.
- d) The boy DOES NOT KISS his mother.
- e) Washington DOES NOT FIX the machine.

Exercício 6

- a) (3)
- b) (4)
- c) (1)
- d) (2)
- e) (5)

Exercício 7

A cat	AN office-boy
A secretary	AN airplane
A boss	AN elegant person
A hospital	AN hour

Exercício 8

AT *Sunshine Travel Agency*
IN a hospital
AT *Hotel Torrão*
IN a coffee shop
IN a supermarket

Aula 26 – Are you having a good time?

Exercício 1

- a) Mario IS NOT eating a hamburger.
- b) Lilian and José ARE NOT dancing.
- c) We ARE NOT resting.
- d) Washington IS NOT fixing a machine.
- e) I AM NOT working today.

Exercício 2

Today is Sunday. Nei IS NOT WORKING. He IS NOT GOING to school. He IS NOT READING a newspaper. He IS NOT SLEEPING. He is resting.

Exercício 3

- a) IS Júlio TYPING a letter?
- b) IS Marta DOING the exercises?
- c) ARE you TAKING photos?
- d) AM I dancing?
- e) ARE YOU sleeping?

Exercício 4

Ligue as perguntas às respostas.

- a) (2)
- b) (3)
- c) (4)
- d) (1)

Exercício 5

- a) The girl is studying.
- b) The man is running.
- c) The boys are playing.

Aula 27 – I usually go to school but today...

Exercício 1

- a) John takes a bus every morning, but this morning he IS TAKING a taxi.
- b) Marta cooks cakes every week, but this week she IS COOKING pies.
- c) Nei usually goes to school by bicycle, but today he IS GOING by bus.
- d) Diana READ the news to Ian every afternoon, but this afternoon she is reading a comic book.

Exercício 2

- a) She USUALLY takes a bus to go to work.
- b) We visit our mother EVERY DAY/EVERY WEEK/EVERY MONTH.
- c) They OFTEN eat a green salad, but NOW they are eating a hamburger.
- d) He fixes machines EVERY DAY, but TODAY he is watching TV.
- e) You write a letter to your friends EVERY MONTH.
- f) They run at Parque do Ibirapuera EVERY MORNING.
- g) I FREQUENTLY read the newspaper.

Aula 28 – Revisão das estratégias de leitura

Exercício 1

- a) Rio de Janeiro.
- b) US\$ 999,00.
- c) Rio Maravilha/Copacabana Othon.
- d) 7 days.
- e) Sailing, fishing, sports são as atividades oferecidas.

Aula 29 – Revisão

Exercício 1

- a) THIS is a catalog.
- b) THIS is my pencil.
- c) THOSE are my newspapers.
- d) THOSE are answering machines.
- e) What is THIS?

Exercício 2

READ a story to Ian.

FEED the baby at eleven o'clock.

DON'T TAKE Ian to the park (it is raining).

DON'T LET Ian watch TV for more than two hours.

MAKE Ian sleep at two o'clock.

Exercício 3

a) Quem enviou o fax foi Mrs. Carter.

b) O fax é para Mr. Richards.

c) A data é August 16th, 1995.

Exercício 4

a) 22 de agosto de 1957.

b) 31 de maio de 1992.

Exercício 5

a) CAN you read this manual in English?

b) I CAN'T stop watching TV.

c) CAN he use this camera?

d) They CAN cross the street.

e) She CAN'T stand much noise.

Exercício 6

a) Marta IS VISITING her mother.

b) Ian IS NOT DRINKING milk.

c) ARE they HAVING a good time?

d) I AM NOT PLAYING chess. I am playing cards.

e) ARE you GOING to the party?

Aula 30 - Exercícios de reforço**Exercício 1**

a) IS

Exercício 2

c) AN officer and A gentleman.

Exercício 3

b) We ARE the champions, my friend.

Exercício 4

d)

GO to school!

BE a good boy!

WASH your hands!

Exercício 5

c)

DO you know Carla?

DOES he sleep all night?

DO we go together?

DOES she work in a hotel?

Exercício 6

d)

He IS SINGING in the rain.

We ARE SINGING in the rain.

You ARE SINGING in the rain.

Exercício 7

c)

Name: DAVID CARTER.

Occupation: TECHNICIAN.

Address: PERDIZ STREET, 432.

Telephone number: 234-5678.

Exercício 8

a) WOULD YOU LIKE some coffee?

Exercício 9

c) He DOESN'T DO the dishes - We DON'T WORK at *Sunshine Travel Agency* -
I DON'T GO to school every day.

Exercício 10

b) Segunda, 14 de novembro de 1995.